

TWIN WALL SQUARE



The TWIN WALL series was designed using modern simulation methods in order to obtain the highest product quality.



PRODUCT SPECIFICATIONS

Working temperature range	-20°C ÷ +55°C
Power consumption	24W
IP protection class	IP65
Lifetime L80B10	≥ 40 000h
Impact resistance	IK07
Protection class	I
Connection	-
Wiring	-
Dimming	DALI 2
Luminous flux tolerance	±10%
Angle of distribution	18°, 36°

DIMENSIONAL DRAWINGS

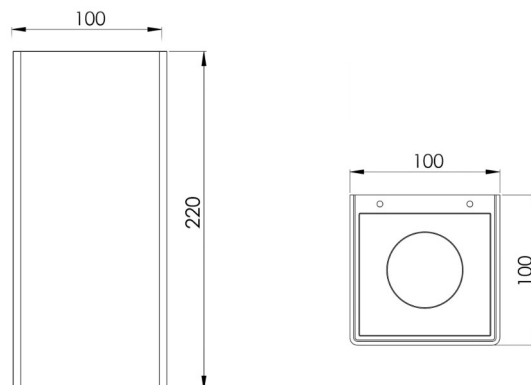

TWIN WALL SQUARE

CONNECTION

Connecting to the power supply should be done when the power supply is off .

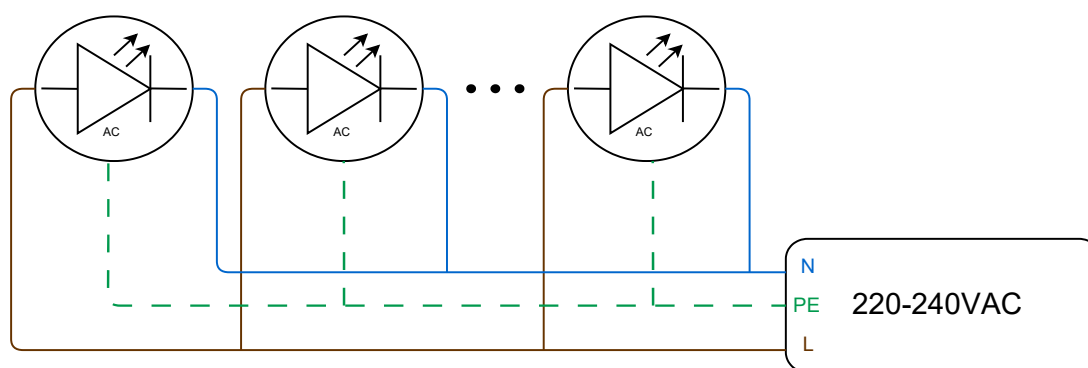

ACCESSORIES

- TWIN WALL MASK mounting accessory

