

INGROUND PATH PRO 12/24V



The INGROUND series was designed using modern simulation methods in order to obtain the highest product quality.



PRODUCT SPECIFICATIONS

| | |
|---------------------------|---------------|
| Working temperature range | -20°C ÷ +55°C |
| Power consumption | 15 W |
| IP protection class | IP67 |
| Lifetime L80B10 | ≥ 60 000h |
| Impact resistance | IK10 |
| Protection class | III |
| Connection | 0.5m |
| Wiring | H07RN-F 2X1.5 |
| Dimming | ON-OFF/PWM |
| Luminous flux tolerance | ±10% |
| Angle of distribution | 40° x 20° |

DIMENSIONAL DRAWINGS

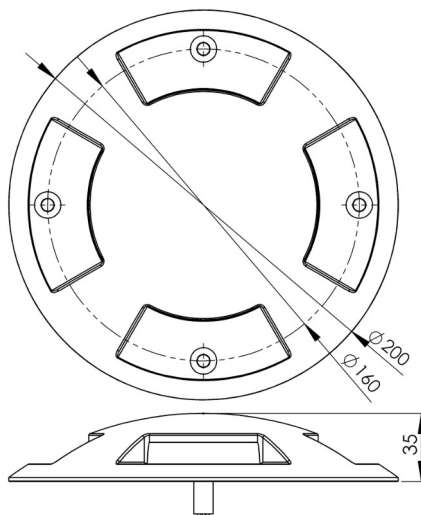

INGROUND PATH PRO 12/24V

CONNECTION

Connecting to the power supply should be done when the power supply is off .

