

INGROUND PATH STANDARD 230V



The INGROUND series was designed using modern simulation methods in order to obtain the highest product quality.



PRODUCT SPECIFICATIONS

Working temperature range	-20°C ÷ +55°C
Power consumption	5W
IP protection class	IP67
Lifetime L80B10	≥ 60 000h
Impact resistance	IK10
Protection class	I
Connection	0.5m
Wiring	H07RN-F 3G1
Dimming	ON-OFF
Luminous flux tolerance	±10%

DIMENSIONAL DRAWINGS

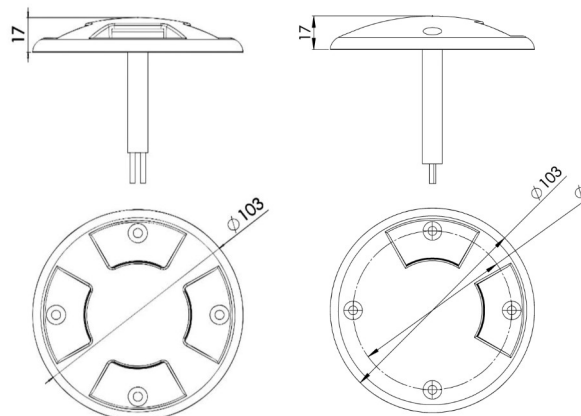

INGROUND PATH STANDARD 230V

CONNECTION

Connecting to the power supply should be done when the power supply is off .

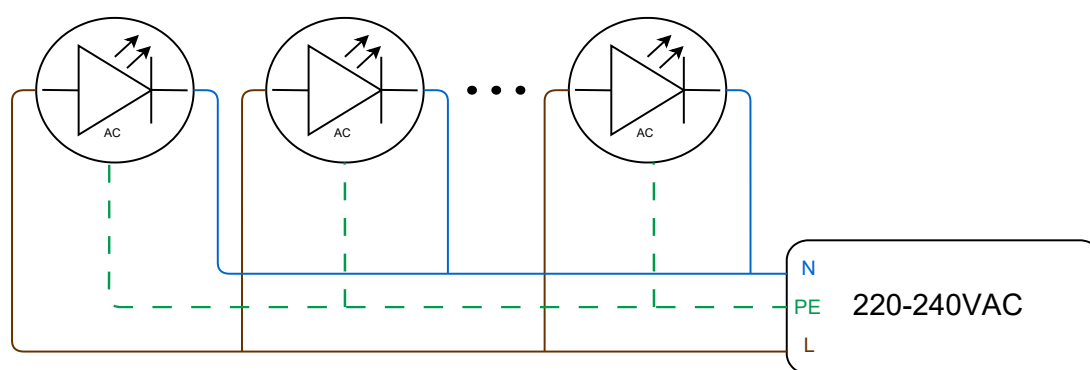

ACCESSORIES

- INGROUND PATH STANDARD MASK

