

### INGROUND ANTI GLARE 12/24V



The INGROUND series was designed using modern simulation methods in order to obtain the highest product quality.



#### PRODUCT SPECIFICATIONS

Working temperature range	-20°C ÷ +55°C
Power consumption	20W
IP protection class	IP69K
Lifetime L80B10	≥ 60 000h
Impact resistance	IK10
Protection class	III
Connection	0.5m
Wiring	H07RN-F 2X1.5
Dimming	ON-OFF/Active Eye Protection System
Luminous flux tolerance	±10%
Angle of distribution	55°

#### DIMENSIONAL DRAWINGS

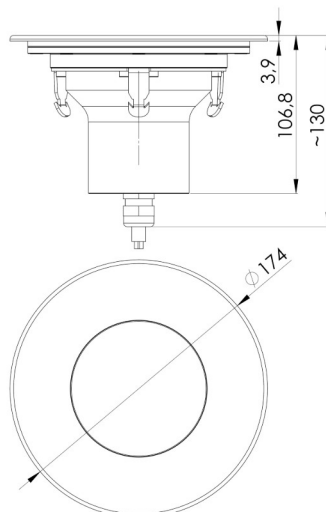

### INGROUND ANTI GLARE 12/24V

#### CONNECTION

Connecting to the power supply should be done when the power supply is off .

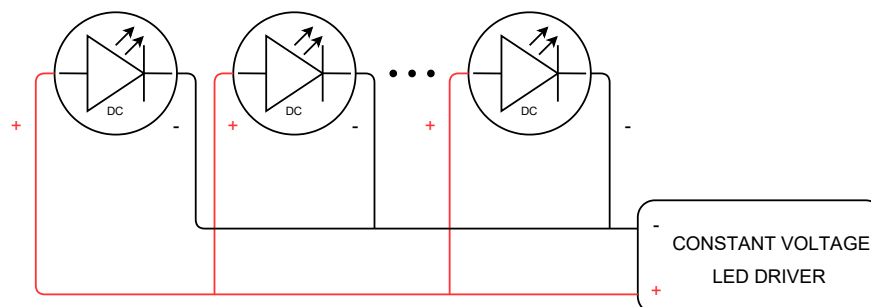

#### ACCESSORIES

- INGROUND ANTI GLARE ABS mounting accessory

